

# Mini Line Mixer

## User Manual

Congratulations on purchasing a Mini Line Mixer! This product is designed to be a small, yet high quality mixer ideal for creating parallel effects systems or any other task requiring the mixing of audio signals. Up to four stereo or mono input signals can be mixed down to a single stereo output.

The Mini Line Mixer uses high quality components for maximum audio quality, including Burr-Brown op-amp chips. The standard 9V power supply is converted internally to a +/-15V supply, providing maximum headroom for any audio signal.

### Inputs/Outputs

**L/TRS Inputs 1-4:** These jacks are the left side inputs for Inputs 1 through 4. These jacks will accept a stereo signal via a ¼" TRS (tip-ring-sleeve) plug if nothing is plugged into the corresponding **R/Mono** jack.

**R/Mono Inputs 1-4:** These jacks are the right side inputs for Inputs 1 through 4. A mono signal at this jack will be sent to both the left and right outputs if nothing is plugged into the corresponding **L/TRS** jack.

**Note:** The jacks labeled **4/Dry** differ from the other input jacks in that they are muted by the front panel **Dry Mute** button. Otherwise, they're identical.

**L/TRS Output:** This jack provides the left side mix output. If nothing is plugged into the **R Output** jack, then this jack will output a stereo signal via a ¼" TRS plug.

**R Output:** This jack provides the right side mix output. If only one output is in use, it is recommended that you use this jack instead of the **L/TRS Output**.

**Dry Mute:** When this button is depressed, the **4/Dry** input jacks are muted. This is typically used when debugging a parallel effects system, and is usually left unmuted.

**Level:** Overall level control. This control ranges from no output (fully counterclockwise) to a 3db boost (fully clockwise). Unity gain is at the 12 o'clock (straight up) position.

**Power In/Out:** Plug in a BOSS type 9VDC, center negative adapter into one of these jacks. The other jack can be used to daisy-chain another device from the same power supply, provided the AC adaptor has sufficient current capacity to power both the Mini Line Mixer and the other device. The Mini Line Mixer is isolated from the power supply, so there is no danger of ground loops through the power supply connection.

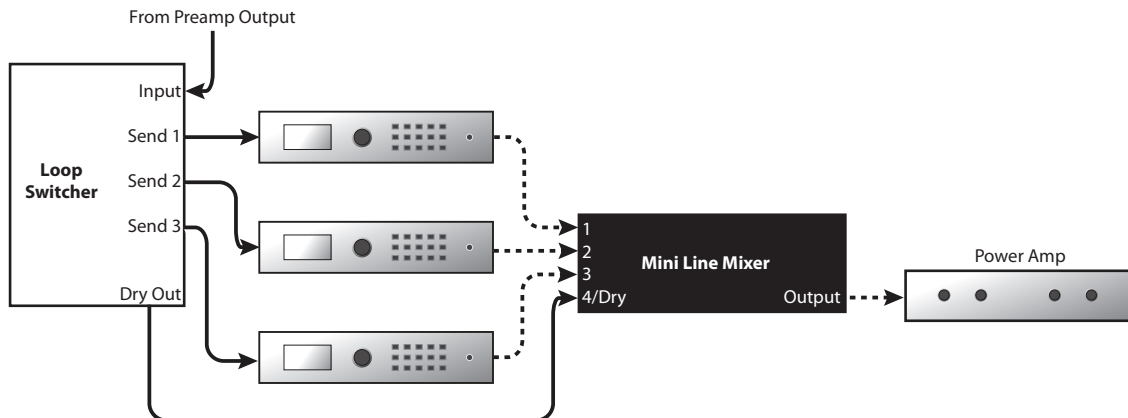

**Mini Line Mixer Example Connection Diagram**  
*(note: stereo connections are denoted by dashed lines)*

The above diagram shows an example of how a parallel effects system can be created with the Mini Line Mixer. An audio loop switcher sends the audio signal to multiple effects processors, which are mixed together along with the dry signal. The output of the Mini Line Mixer is sent to a stereo power amp. Please refer to the RJM Music web site for more connection diagrams and other how-to information.

**A note on signal impedance:** The Mini Line Mixer is designed to work with low impedance signals, like those in an amplifier's effects loop. In order to use it with a high impedance signal like an unamplified guitar signal, the signal needs to go through a buffer before reaching the Mini Line Mixer.

## Specifications

<b>Dimensions</b>	Quarter-rack enclosure 4 (W) x 1.5 (H) x 4 (D) inches 10.2 (W) x 3.8 (H) x 10.2 (D) cm
<b>Weight</b>	11.8 ounces 335 grams
<b>Power</b>	9VDC @ 150mA <i>(can draw more current under unusual circumstances – input levels much higher than standard audio levels or shorted outputs)</i> 5.5mm OD, 2.1mm ID x 9.5mm barrel connector, center negative



RJM Music Technology, Inc.  
 2525 Pioneer Ave. Suite 2  
 Vista, CA 92081  
 Tel: +1-760-597-9450  
 Email: support@rjmmusic.com