

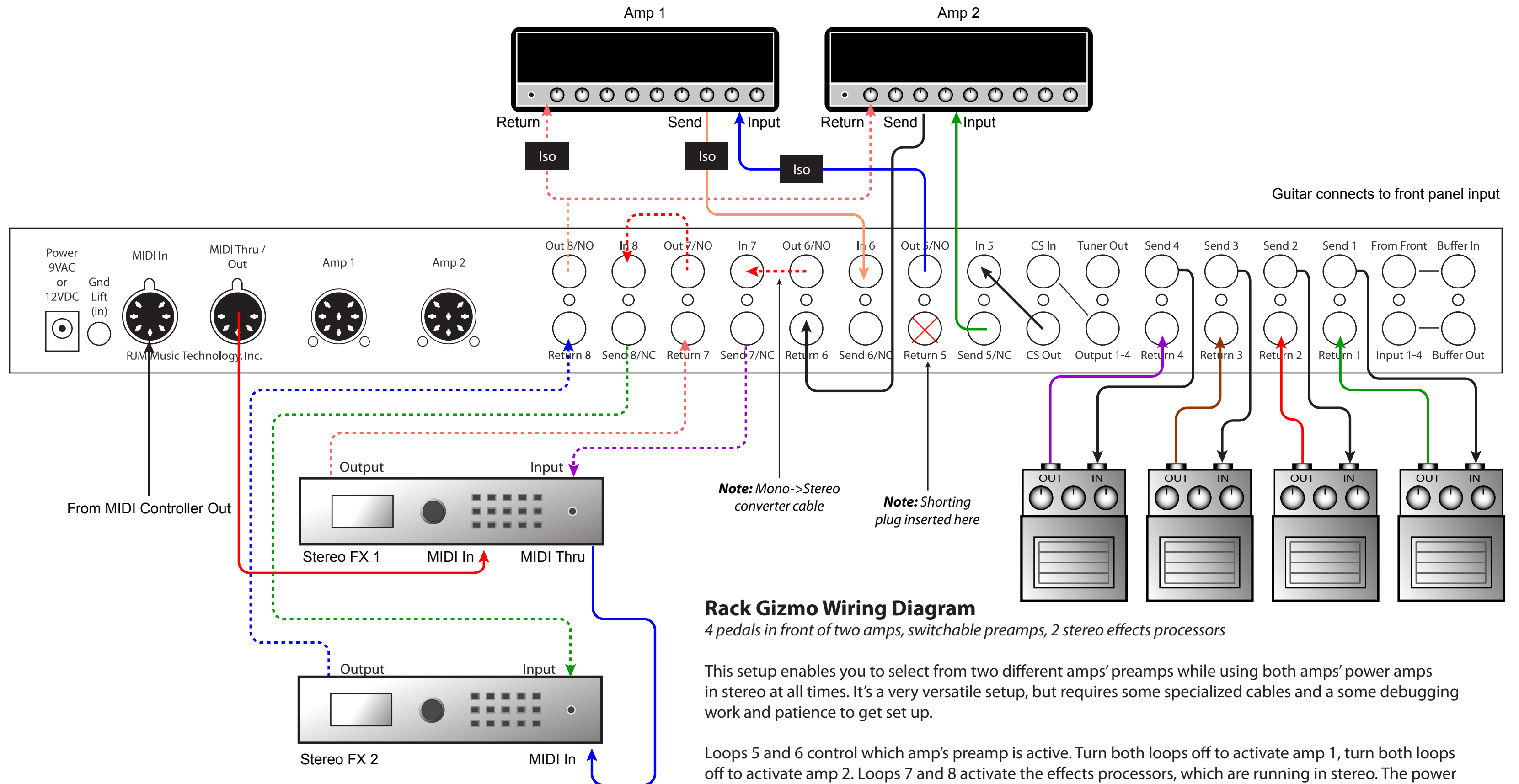

Rack Gizmo Wiring Diagram



Rack Gizmo Wiring Diagram

4 pedals in front of two amps, switchable preamps, 2 stereo effects processors

This setup enables you to select from two different amps' preamps while using both amps' power amps in stereo at all times. It's a very versatile setup, but requires some specialized cables and a some debugging work and patience to get set up.

Loops 5 and 6 control which amp's preamp is active. Turn both loops off to activate amp 1, turn both loops off to activate amp 2. Loops 7 and 8 activate the effects processors, which are running in stereo. The power amps of both amps are always active and running in stereo.

Isolation transformers are used to eliminate ground loops. It's best to try everything without the transformers and if you have hum, add them one at a time until the hum goes away.

Note: Dashed lines indicate stereo (TRS) connections. The dashed "Y" cable is an insert cable. (stereo connector on one end, separate left and right connectors on the other end). There is a mono to stereo converter cable between loops 6 and 7, and there is a shorting plug (a plug with tip connected to ground) in the Return 5 jack.