

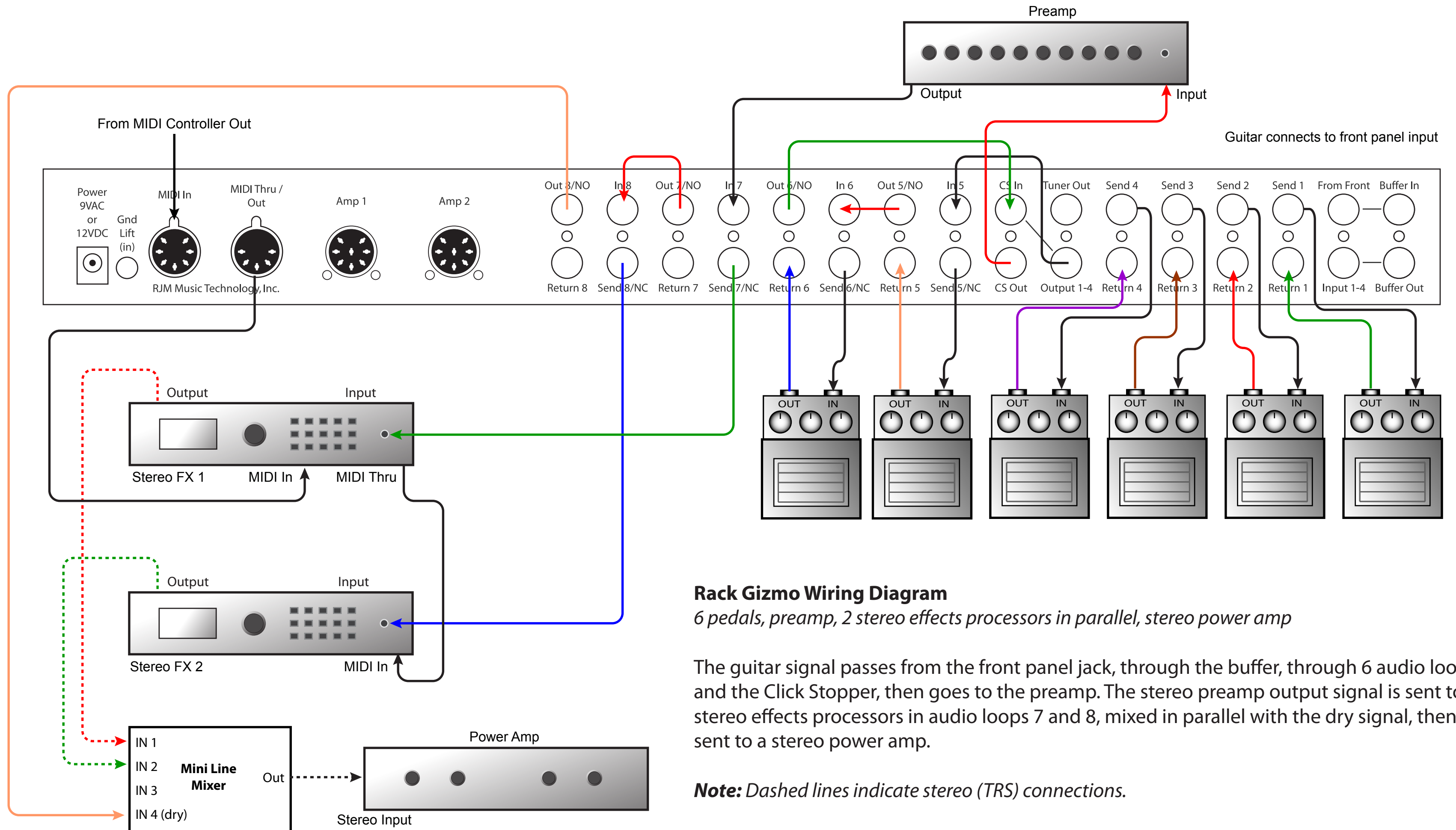

Rack Gizmo Wiring Diagram



Rack Gizmo Wiring Diagram

6 pedals, preamp, 2 stereo effects processors in parallel, stereo power amp

The guitar signal passes from the front panel jack, through the buffer, through 6 audio loops and the Click Stopper, then goes to the preamp. The stereo preamp output signal is sent to two stereo effects processors in audio loops 7 and 8, mixed in parallel with the dry signal, then sent to a stereo power amp.

Note: Dashed lines indicate stereo (TRS) connections.